



Use this reference to complete your site plan form

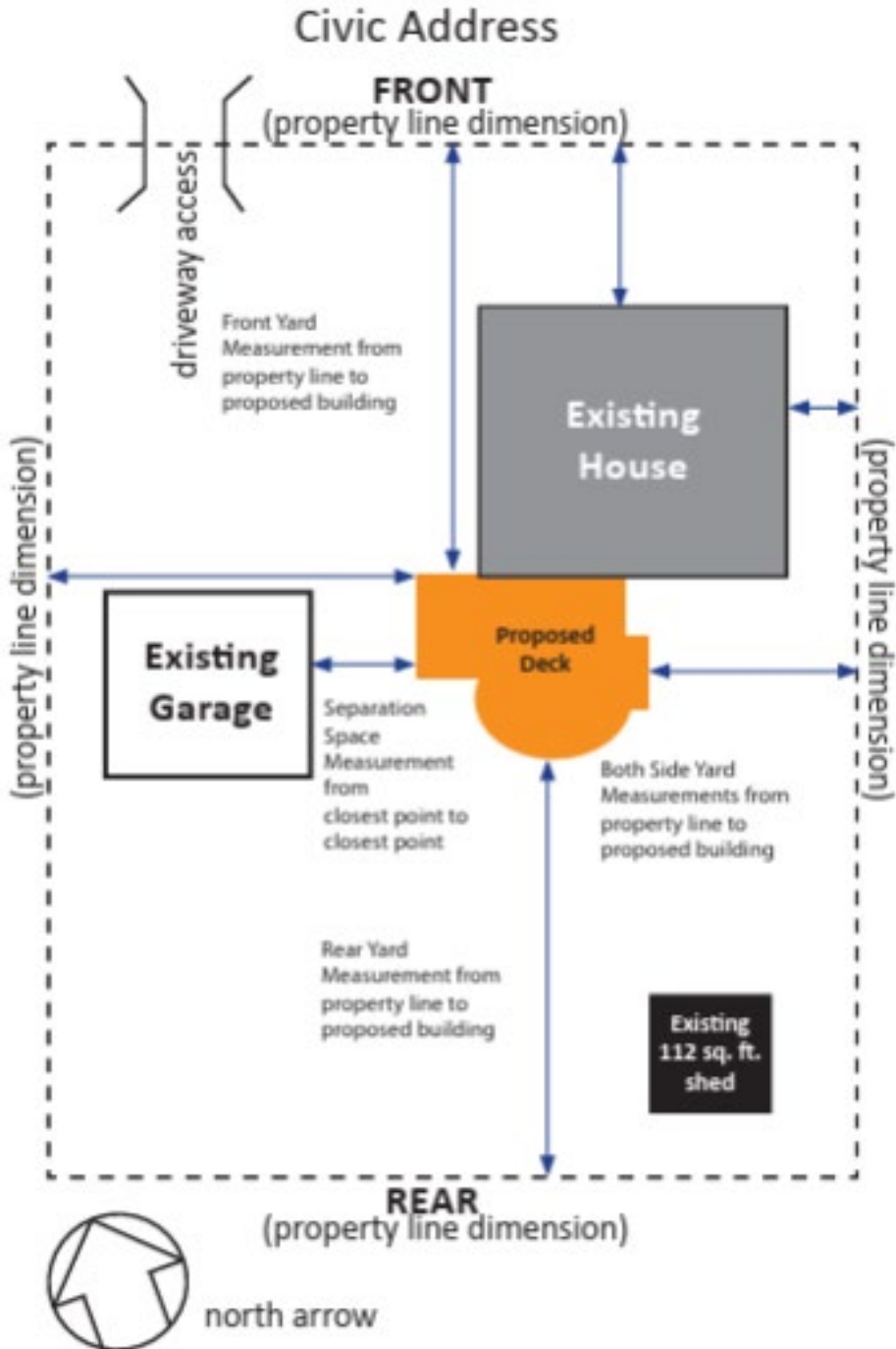
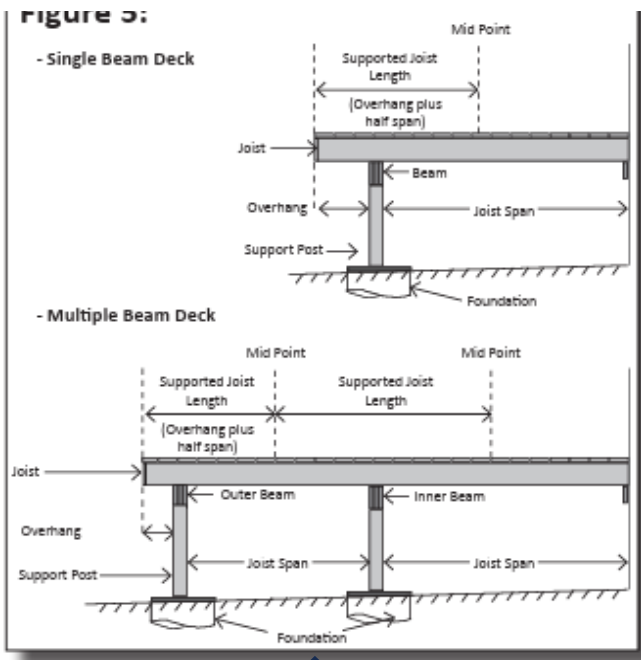
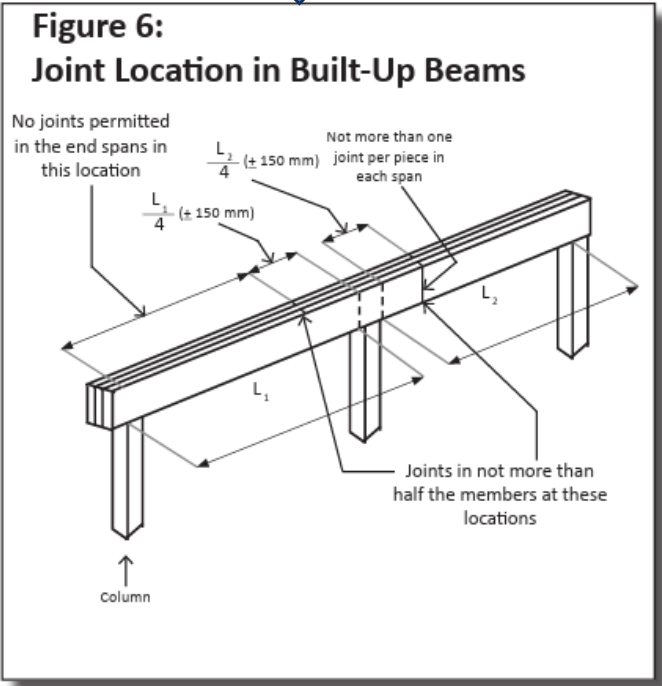

Figure 5.



Parts of a deck with

How to build a beam with Splices



General Requirements:

- Decks over 592 sqft require engineer stamped drawings
- Decks over 72" from grade require engineer stamped drawings
- Posting over 8' require engineer stamped drawings
- Surface pads cannot support a roof
- Access must be provided to permit releveling if surface pads used
- Posting must support entire width of beam (6X6 for 3 ply beam)
- Stairs with more than 3 risers require handrail.
- Decks with two or more tiers require engineer stamped drawings
- Permits are required for anything over 24" from grade
- Benches are not to be counted as guards

STAIRS

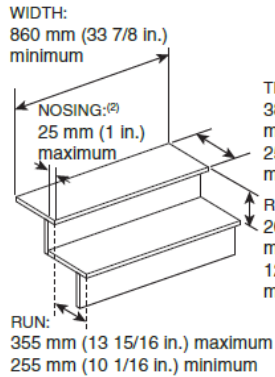

Private stairs

- WIDTH:
- for buildings of residential occupancy, 900 mm (36 in.) minimum
 - for other buildings, not less than 900 mm (36 in.) or 8 mm (1/4 in.) per person, whichever is greater⁽¹⁾

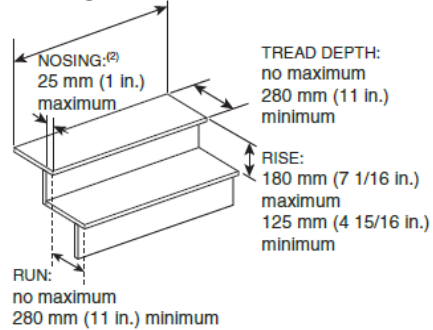

Public stairs

EG0029C

GUARDS

Every exterior walking surface (e.g., landing, porch, balcony, mezzanine, gallery or raised walkway) to which access is provided must be protected by guards on all open sides where the difference in elevation, H, between the walking surface and the adjacent surface is more than 600 mm (24 in.).

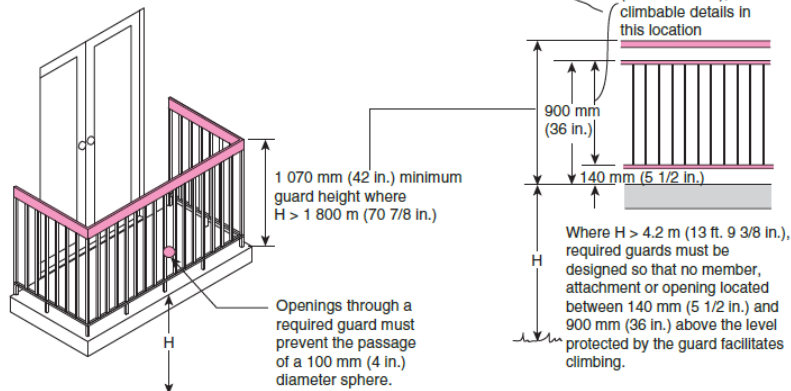
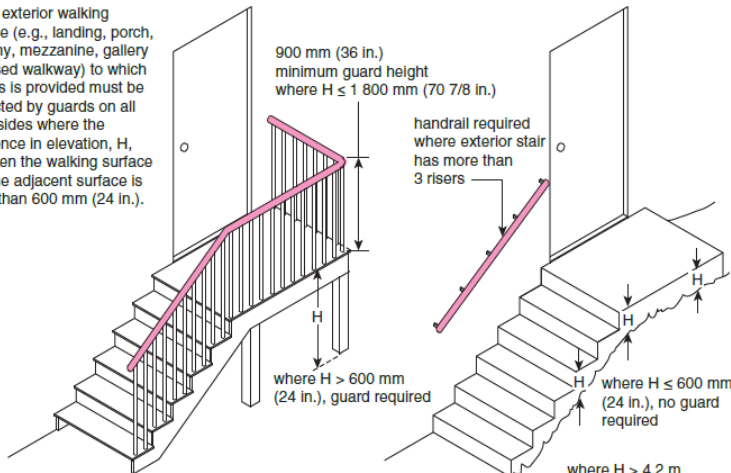

EG00294C